



PLUMB LINE GL

APPLICATION

The inclination as well as the horizontal displacement of above and below ground structures, as well as of production plants, is of decisive importance for the evaluation of their behaviour and stability. A plumb installation can act as reference axis, from which the displacements observed at different levels can give the deflection line.

A plumb installation can be manufactured either as a plumb line or as an inverted plumb line, for which the wire is fixed at its upper or lower end respectively. Depending on whether this fixation is on the structure itself or in the foundation rock, either the inclination of the structure itself, or also its displacement relative to an external reference point can be determined.

A combination of the two types of installation gives

the maximum information. For a dam for instance, a plumb line anchored on the crest yield the inclination and deflection line relative to the crest, whilst a float line, or inverted pendulum, fixed deep in the foundation rock, gives the movement relative to the surrounding rock.

DESCRIPTION

A pendulum system consists of the plumb reference point FP, the plumb wire LTD, the plumb weight G and the damping vessel D.

For manual measuring a Coordiscope KK84 (N or D) is used. The contactless remote measuring instrument Telot VDD2E can be installed for permanent surveillance.

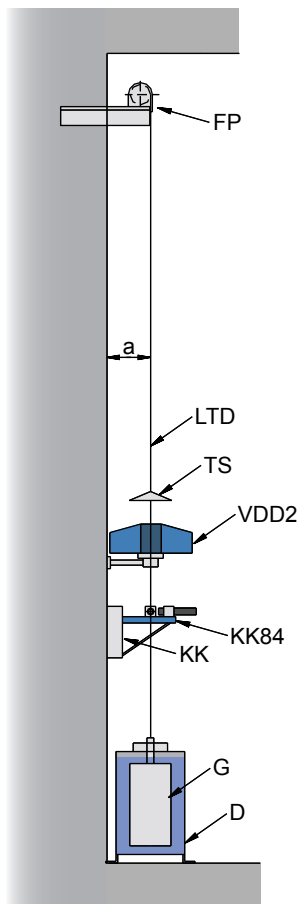

Plumb line GL20, GL50

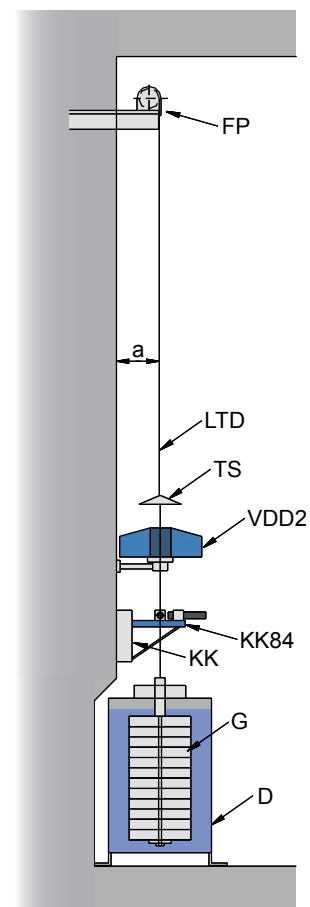

Plumb line GL100, GL200

© HUGGENBERGER AG 2005



PLUMB LINE GL

TECHNICAL DATA

Type	GL20-150	GL50-100	GL100-150	GL200-150
Plumb weight	200N	500N	1000N	2000N
Plumb wire	Ø 1mm		Ø 2mm	
Max. wire length (C)	~20m	~50m	<150m	>150m
Measuring range (A)	150mm	100mm	150mm	150mm
Measurement with	B	B	B	B

Explanations

- A Without moving the damping vessel
- B Coordiscope, Telelot all types
- C The maximum possible plumb wire length is mainly influenced by two factors:
 1. Measuring method with or without touching the wire
 2. Air current in the plumb pit or generally in the building